

Zero Leakage Isolating Damper

5.1 Type CID-01

SPECIFICATION

Casing

The damper casing is formed from 3.0 mm thick sheet steel into a rigid channel section to ensure proper alignment of blades and shafts. Where circular dampers are required, additional spigot adaptors are used which increase the damper insertion length from 350 to 450 mm.

Blades

The blades are a formed single-skin of 3.0 mm sheet steel fitted with a closed cell pad that seals against a frame within the damper casing to provide 100% isolation.

Shafts

Continuous shafts \varnothing 19.05 mm with welded pivoted-blade support at each end.

Linkage

Parallel action linkage consisting of drive levers and bosses connected by flat bar link bars, driven through stainless steel pins. All linkage is contained within the depth of the casing.

Bearings

Phosphor bronze self lubricated plain 'Oilite' bushes fitted into bearing bosses welded to the outside of the casing.

Shaft Seals

Lipseal type fitted into each bearing boss.

Operation

Pneumatic Actuator.
Electric Actuator.
Manual Handwheel.

Options

Earth continuity bosses.
Lifting lugs.
Solenoid Valves.
Remote Indication - Microswitches.
Local Indication.

Other variations to suit clients' specific requirements are also available.

DESCRIPTION

The type CID-01 Isolation Damper has been specifically designed to meet the tight shut-off requirements of the industrial and nuclear markets, where isolation of ducting for filter replacement or duct inspection is required, without shutting down complete systems. These versatile dampers can be automatically or manually operated and can be supplied with pre-drilled flanges to ease installation. The dampers may be installed vertically or horizontally with the air flow in one direction.

Zero Leakage Isolation Damper

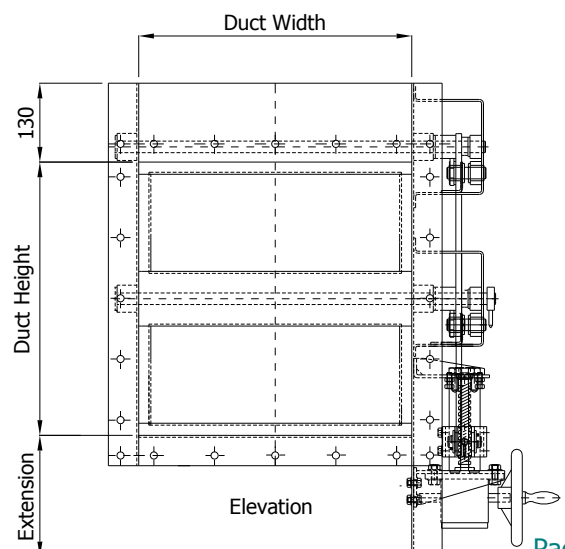
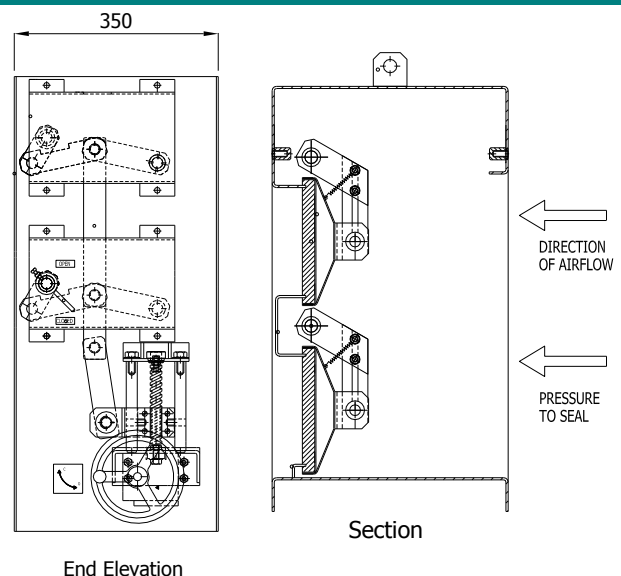

5.1.1 Type CID-01

Zero Leakage Isolating Damper

Zero Leakage Isolation Damper

INSTALLATION AND ASSEMBLY

Leakage:

Each damper is tested to ensure there is zero leakage through the blades and casing - as follows:-

Test Procedure:

Each complete damper assembly is subjected to a works pressure test of 5000 Pa for one hour. The upstream end of the damper is sealed during the test and the pressurizing source removed. After one hour the pressure is checked to ensure that it has not dropped taking into consideration any changes in air temperature.

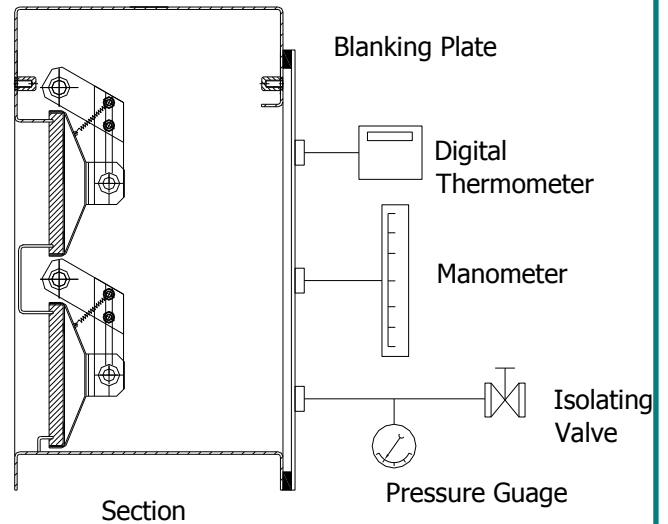

TEST ARRANGEMENT

OPEN PRESSURE DROP CHARACTERISTIC CURVE

Tolerance $\pm 15\%$

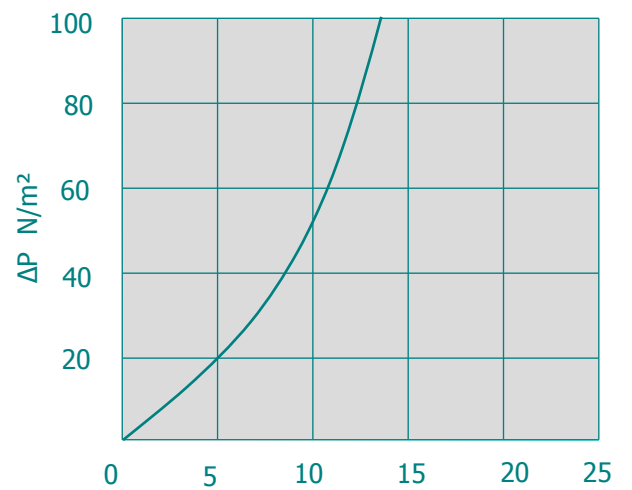

Face Velocity m/sec. (Based on duct area)

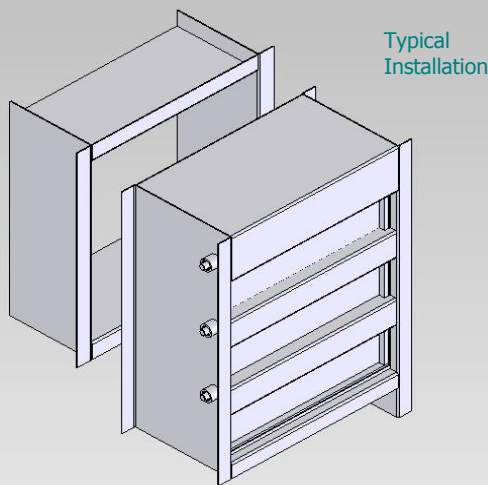

Multiple Assemblies

