

# Heavy Duty Shut-Off Control Damper

## 4.1 Type CCD-01

### SPECIFICATION

#### Casing

The damper casing is formed from 3.0 mm thick sheet steel into a rigid channel section to ensure proper alignment of blades and shafts. Damper units in excess of 1275 mm width shall be manufactured as a multiple assembly. Where circular dampers or dampers with width or height dimensions less than 150 mm are required, additional spigot adaptors are used which increase the damper insertion length from 300 to 400 mm.

#### Blades

The blades are a formed double-skin aerofoil section of 1.5 mm sheet metal. Blade stops at the top and bottom of the casing and sprung side seals provide excellent low leakage characteristics.

#### Shafts

Continuous  $\varnothing$  19.05 mm with blades plug welded at each end.

#### Linkage

Opposed action linkage consisting of drive levers and bosses connected by flat bar link bars, driven through stainless steel pins. All linkage is contained within the depth of the damper casing.

#### Bearings

Phosphor bronze self lubricated 'Oilite' flanged bushes.

#### Operation

Pneumatic Actuator.  
Electric Actuator.  
Hand Locking Quadrant.

#### Options

Materials can be stainless steel, galvanized mild steel or other materials to suit the clients' specific requirements.  
Earth continuity bosses.  
Lifting lugs.  
Flame retardant PVC blade seals.  
Integral or removable enclosures for housing control equipment.  
High temperature bearings.  
Shaft seals to provide airtight casings.  
Other variations to suit clients' specific requirements are also available.

### DESCRIPTION

The type CCD-01 Heavy Duty Shut-Off and Control Damper has been specifically designed to meet the rigorous duty required in a hazardous environment where robust construction and dependable operation are of prime importance. These versatile dampers are suitable for automatic and manual operation and may be used for: system balancing, fan shut-off, fresh air re circulation and many more functions. To ease installation all dampers are supplied with pre-drilled flanges and are designed to be suitable for mounting in any attitude with the airflow in either direction.

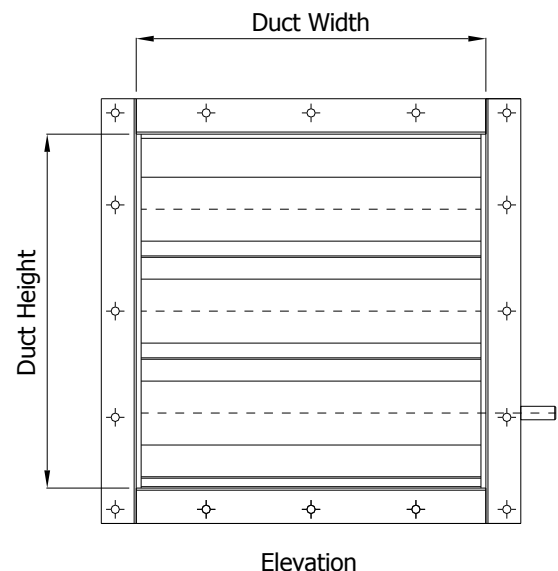
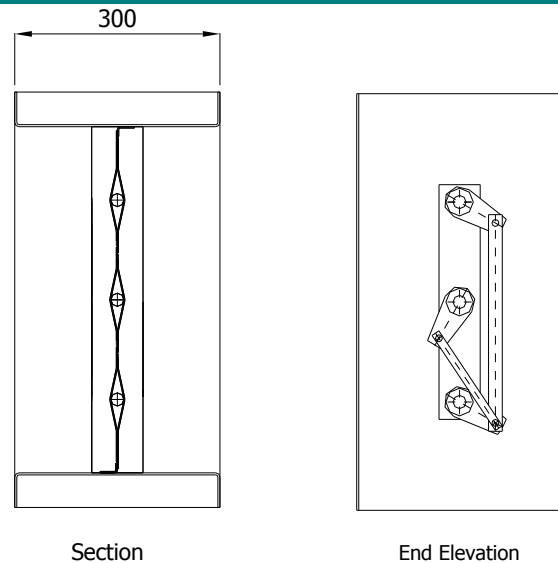

# 4.1.1 Type CCD-01

# Heavy Duty Shut-Off Control Damper

## Control Damper

### INSTALLATION AND ASSEMBLY

**Note:**

Larger dampers can be constructed by joining multiple assemblies together.

An approved fire-resistant sealant should be inserted between the damper and duct to ensure a good seal.

**Note:**

Each section shall have a drive spindle which can be linked together externally or driven independently.

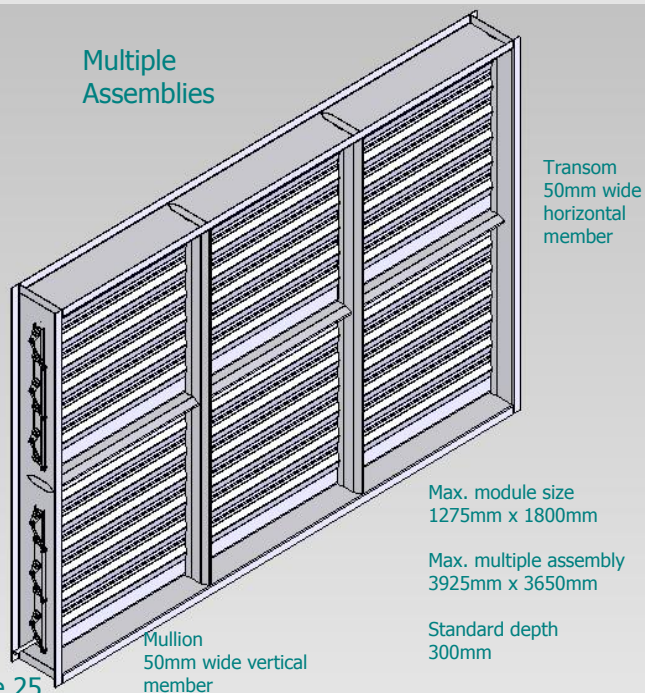
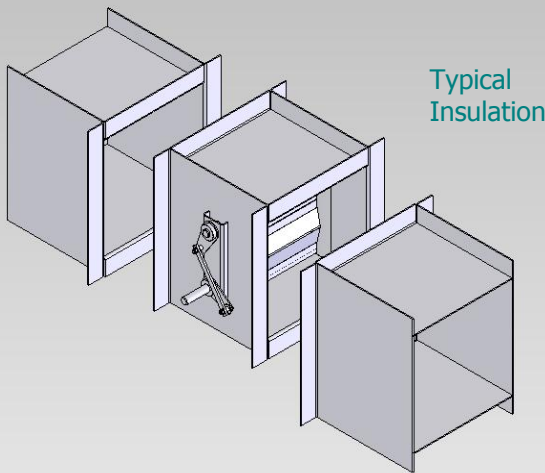

### LEAKAGE CHARACTERISTIC CURVE

Tolerance ±15%

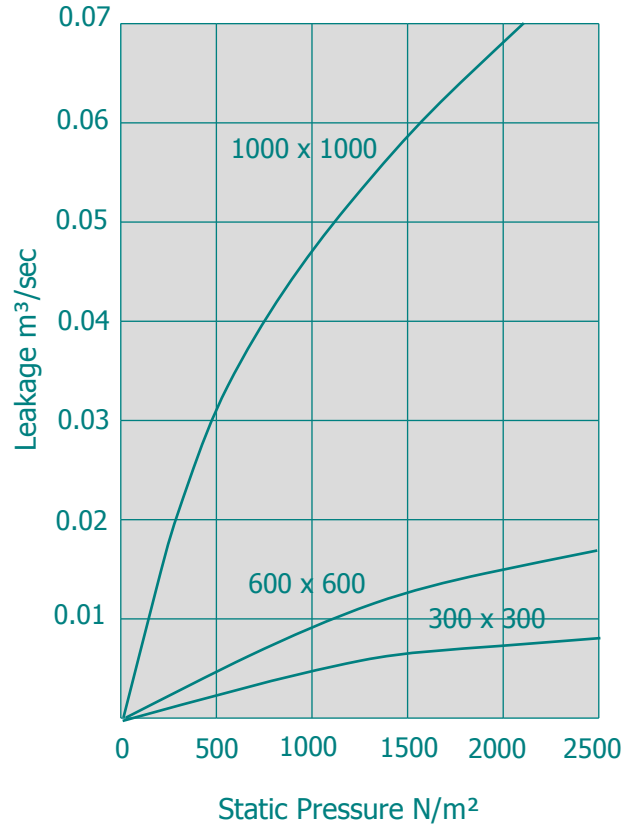

### OPEN PRESSURE DROP CHARACTERISTIC CURVE

Tolerance ±15%

